

>> HSS KEGESENKER, DIN 335 C, 90°

Einsatzbereich:

Für alle E- und NE-Metalle, Kunststoffe hart und weich. Universell einsetzbares Entgrat- und Senkwerkzeug für Bohrungen aller Art. Sehr gute Schneideigenschaften ohne „Rattermarken“, durch radialen Hinterschliff leicht nachschärfbar an der Spanfläche.

- [HITZEBESTÄNDIG]** bis 500° Schneidtemperatur
- [PRÄZISE]** durch modernes Schleifverfahren
- [INDUSTRIEQUALITÄT]** für NC-Maschinen geeignet

HSS COUNTERSINKS, DIN 335 C, 90°

Range of application:

For ferrous and non-ferrous metals, synthetic materials soft and hard. Universal deburring and sink tool for all kind of borings. Excellent cutting features guarantee a smooth surface without burrs; profile relief facilitates an easy regrind.

- [HEAT-RESISTANT]** up to 500° C cutter temperature
- [PRECISE]** thanks to state-of-the-art grinding process
- [INDUSTRIAL QUALITY]** suitable for NC machines

SVASATORI CONICI HSS, DIN 335 C, 90°

Impiego:

Adatti per tutti i materiali ferrosi, non ferrosi, plastiche dure e dolci, per sbavature e svasature di tutti i tipi di fori. Ottime proprietà di taglio senza segni di "rigature", mentre la spoglia radiale permette una facile riaffilatura.

- [RESISTENTI AL CALORE]** sui taglienti fino a 500° C
- [PRECISI]** grazie alla moderna lavorazione
- [QUALITÀ INDUSTRIALE]** adatti per macchine utensili CN



HSS **DIN 335**

Form Form Forma **C** **90°**

Oberfläche: blank
Surface: bright
Superficie: lucida

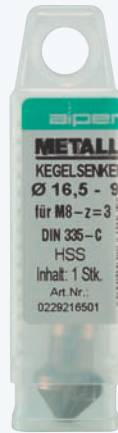

Einzelverpackung mit SB-Auhänger
Single packing with tag
Imballo singolo con gancio

- ▶ Für unser umfangreiches Sortiment an HSS- und VHM-Werkzeugen fordern Sie bitte den MAYKESTAG-Katalog an!
- ▶ For our extensive range of HSS and solid carbide cutting tools please request the MAYKESTAG catalogue!
- ▶ Per il programma completo di utensili in HSS e metallo duro integrale richiedete il catalogo MAYKESTAG!

d1 mm	d2 mm	d3 ₄₅ mm	l1 mm	Z	Code 2292 Art.-Nr.	Inh. Cont.	€/Stk. €/pc.
6,30	1,50	5	45	3	0 2292006301 00	1	8,27
8,30	2,00	6	50	3	0 2292008301 00	1	8,90
10,40	2,50	6	50	3	0 2292010401 00	1	9,84
12,40	2,80	8	56	3	0 2292012401 00	1	11,20
16,50	3,20	10	60	3	0 2292016501 00	1	14,54
20,50	3,50	10	63	3	0 2292020501 00	1	18,56
25,00	3,80	10	67	3	0 2292025001 00	1	23,12



>> HSS COBALT KEGESENKER, DIN 335 C, 90°

Einsatzbereich:

Für alle E- und NE-Metalle, Kunststoffe hart und weich. Universell einsetzbares Entgrat- und Senkwerkzeug für Bohrungen aller Art. Sehr gute Schneideigenschaften ohne „Rattermarken“, durch radialen Hinterschliff leicht nachschärfbar an der Spanfläche.

HEIZBESTÄNDIG	PRÄZISE	INDUSTRIEQUALITÄT
bis 600° Schneidentemperatur	durch modernes Schleifverfahren	für NC-Maschinen geeignet

HSS COBALT COUNTER-SINKS, DIN 335 C, 90°

Range of application:

For ferrous and non-ferrous metals, synthetic materials soft and hard. Universal deburring and sink tool for all kind of borings. Excellent cutting features guarantee a smooth surface without burrs; profile relief facilitates an easy regrind.

HEAT-RESISTANT	PRECISE	INDUSTRIAL QUALITY
up to 600° C cutter temperature	thanks to state-of-the-art grinding process	suitable for NC machines

SVASATORI HSS COBALTO, DIN 335 C, 90°

Impiego:

Adatti per tutti i materiali ferrosi, non ferrosi, plastiche dure e dolci, per svasature e svasature di tutti i tipi di fori. Ottime proprietà di taglio senza segni di "rigature", mentre la spoglia radiale permette una facile riaffilatura.

RESISTENTI AL CALORE	PRECISI	QUALITÀ INDUSTRIALE
fino a 600° C	grazie alla moderna lavorazione	adatti per macchine utensili CN

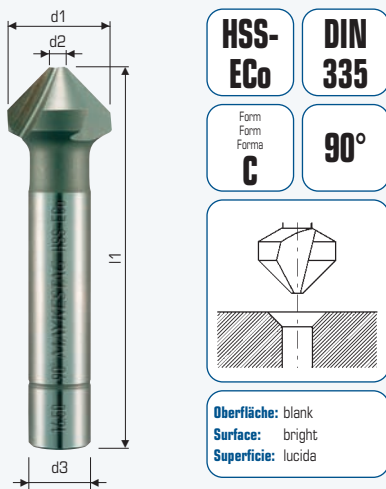

HSS-ECO **DIN 335**

Form Form Forma **C** **90°**

Oberfläche: blank
Surface: bright
Superficie: lucida



Einzelverpackung mit SB-Aufhänger
Single packing with tag
Imballo singolo con gancio

- Für unser umfangreiches Sortiment an HSS- und VHM-Werkzeugen fordern Sie bitte den MAYKESTAG-Katalog an!
- For our extensive range of HSS and solid carbide cutting tools please request the MAYKESTAG catalogue!
- Per il programma completo di utensili in HSS e metallo duro integrale richiedete il catalogo MAYKESTAG!

d1 mm	d2 mm	d3 ₉₀ mm	l1 mm	Z	Code 2290 Art.-Nr.	Inh. Cont.	€/Stk. €/pc.
4,30	1,30	4	40	3	0 2290004301 00	1	9,46
5,00	1,50	4	40	3	0 2290005001 00	1	9,14
5,30	1,50	4	40	3	0 2290005301 00	1	9,35
6,00	1,50	5	45	3	0 2290006001 00	1	9,51
6,30	1,50	5	45	3	0 2290006301 00	1	9,51
8,00	2,00	6	50	3	0 2290008001 00	1	10,52
8,30	2,00	6	50	3	0 2290008301 00	1	10,98
9,40	2,20	6	50	3	0 2290009401 00	1	11,75
10,00	2,50	6	50	3	0 2290010001 00	1	12,63
10,40	2,50	6	50	3	0 2290010401 00	1	13,02
11,50	2,80	8	56	3	0 2290011501 00	1	13,57
12,40	2,80	8	56	3	0 2290012401 00	1	13,87
13,40	2,90	8	56	3	0 2290013401 00	1	14,68
15,00	3,20	10	60	3	0 2290015001 00	1	17,05
16,50	3,20	10	60	3	0 2290016501 00	1	17,05
19,00	3,50	10	63	3	0 2290019001 00	1	23,09
20,50	3,50	10	63	3	0 2290020501 00	1	23,32
23,00	3,80	10	67	3	0 2290023001 00	1	30,14
25,00	3,80	10	67	3	0 2290025001 00	1	31,35
31,00	4,20	12	71	3	0 2290031001 00	1	48,09



>> HSS KEGESENKER 90° MIT 1/4"-SECHSKANTSCHAFT

Einsatzbereich:

Zum Senken, Anfasen und Entgraten, für Metall- und Kunststoffbearbeitung. Zur direkten Verwendung in Elektro-Handbohrmaschinen, Elektro-Schraubern und Akku-Maschinen mit Sechskantaufnahme oder über magnetischen Universalhalter.

[PRÄZISE] [STANDFEST]

durch modernes Schleifverfahren

durch HSS-Stahl

HSS COUNTERSINK 90° WITH 1/4" HEXAGONAL SHANK

Range of application:

Countersink and deburring tool suitable for either metal or synthetic materials. Manufactured with 1/4" hexagonal shank for direct use in standard chuck, cordless drills or through a magnetic bit holder.

[PRECISE] [LONG-LASTING]

thanks to state-of-the-art grinding process

thanks to high-speed steel

SVASATORI CONICI HSS, 90°, CODOLO ESAGONALE 1/4"

Impiego:

Per svasatura, smussatura, sbavatura di materiali ferrosi e plastici. Adatti per elettroutensili portatili, avvitatori a batteria o con mandrini magnetici universali.

[PRECISI] [ELEVATA DURATA]

grazie alla moderna lavorazione

grazie all'acciaio HSS

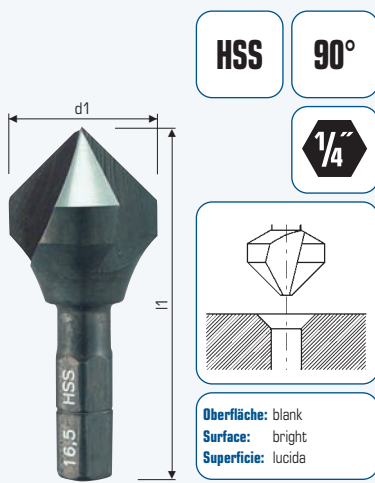

Einzelverpackung mit SB-Aufhänger
Single packing with tag
Imballo singolo con gancio

	d1 mm		l1 mm	Z	Code 720 Art.-Nr.	Inh. Cont.	€/Stk. €/pc.
M3	6,30	1/4"	31	3	00 720006301 00	1	7,00
M4	8,30	1/4"	31	3	00 720008301 00	1	8,80
M5	10,40	1/4"	34	3	00 720010401 00	1	11,88
M6	12,40	1/4"	35	3	00 720012401 00	1	13,43
M8	16,50	1/4"	40	3	00 720016501 00	1	16,89
M10	20,50	1/4"	41	3	00 720020501 00	1	21,07



>> HSS COBALT ENTGRAT-SENKER MIT QUERLOCH-BOHRUNG

Einsatzbereich:

Die günstige Schneidengeometrie ergibt einen leichten schälenden Schnitt. Die Späne werden in Schafrichtung abgeführt und können die Senkung nicht beschädigen. Zum leichten und ratterfreien Entgraten von Bohrungen. Besonders geeignet für weiche langspanende Werkstoffe.

STANDFESTER

durch HSS Cobaltstahl

PRÄZISE

durch modernes Schleifverfahren

HSS COBALT SLOTTED COUNTERSINK HOLE TYPE

Range of application:

Countersink and deburring tool with through hole which is ideal for long chip materials, such as aluminium and very effective on both hard and softwoods. Spoil is removed through centre of cutter to prevent damage to tool.

LONGER LASTING

thanks to cobalt HSS

PRECISE

thanks to state-of-the-art grinding process

SVASATORI – SBAVATORI HSS COBALTO CON FORO TRASVERSALE

Impiego:

La particolare geometria dei taglienti permette di ottenere un taglio alesante. I trucioli vengono evacuati in direzione del codolo senza danneggiare la svasatura. Particolarmente adatti per materiali dolci a truciolo lungo.

ELEVATA DURATA

grazie all'acciaio HSS Cobalto

PRECISI

grazie alla moderna lavorazione

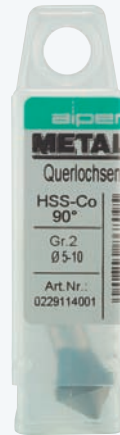

Einzelverpackung mit SB-Auhänger
Single packing with tag
Imballo singolo con gancio

Größe Size Dimensioni	d1 mm	d3 mm	Bereich Range Intervallo Ø mm	Code 2291 Art.-Nr.	Inh. Cont.	€/Stk. €/pc.
1	10,00	6	2- 5	0 2291010001 00	1	11,15
2	14,00	8	5-10	0 2291014001 00	1	15,23
3	21,00	10	10-15	0 2291021001 00	1	28,31
4	28,00	12	15-20	0 2291028001 00	1	54,07
5	35,00	15	20-25	0 2291035001 00	1	92,16

